

MHS Enhanced Service Advantage Cartridge HD Secondary Belt Cleaner

Installation, Operation and Maintenance Manual

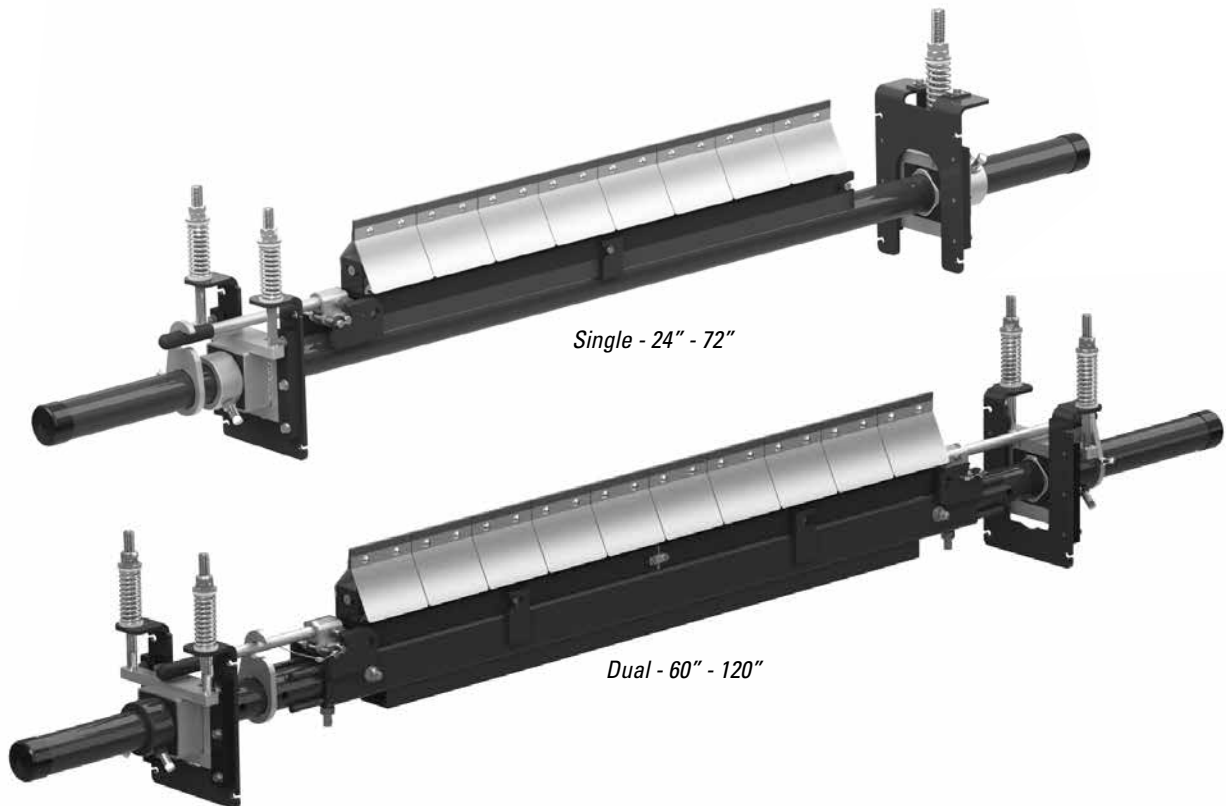

MHS ESAC HD Secondary Cleaner

Serial Number: _____
Purchase Date: _____
Purchased From: _____
Installation Date: _____

Serial number information can be found on the Serial Number Label included in the Information Packet found in the cleaner carton.

This information will be helpful for any future inquiries or questions about belt cleaner replacement parts, specifications or troubleshooting.

Table of Contents

Section 1 - Important Information	4
1.1 General Introduction.....	4
1.2 User Benefits.....	4
1.3 Service Option.....	4
Section 2 - Safety Considerations and Precautions	5
2.1 Stationary Conveyors.....	5
2.2 Operating Conveyors.....	5
Section 3 - Pre-Installation Checks and Options	6
3.1 Checklist.....	6
3.2 Optional Installation Accessories	7
Section 4 - Installation Instructions	8
4.1 Installation Instructions - MHS ESAC Single Cartridge	8
4.2 Installation Instructions - MHS E2SAC Dual Cartridge	12
4.3 Cartridge Replacement Instructions	16
4.4 Push-up Tensioning Instructions.....	19
Section 5 - Pre-Operation Checklist and Testing	20
5.1 Pre-Op Checklist.....	20
5.2 Test Run the Conveyor	20
Section 6 - Maintenance	21
6.1 New Installation Inspection.....	21
6.2 Routine Visual Inspection.....	21
6.3 Routine Physical Inspection	21
6.4 Maintenance Log.....	22
6.5 Cleaner Maintenance Checklist	23
Section 7 - Troubleshooting	24
Section 8 - Specs and CAD Drawing	25
8.1 Specs and Guidelines	25
8.2 CAD Drawing - MHS ESAC with C-Tips.....	26
8.3 CAD Drawing - MHS ESAC with V-Tips.....	27
8.4 CAD Drawing - MHS E2SAC with C-Tips	28
8.5 CAD Drawing - MHS E2SAC with V-Tips.....	29
Section 9 - Replacement Parts	30
9.1 Replacement Parts	30
Section 10 - Other Flexco Conveyor Products	31

Section 1 - Important Information

1.1 General Introduction

We at Flexco are very pleased that you have selected an MHS ESAC HD Secondary Cleaner for your conveyor system.

This manual will help you to understand the operation of this product and assist you in making it work up to its maximum efficiency over its lifetime of service.

It is essential for safe and efficient operation that the information and guidelines presented be properly understood and implemented. This manual will provide safety precautions, installation instructions, maintenance procedures and troubleshooting tips.

If, however, you have any questions or problems that are not covered, please contact your field representative or our Customer Service Department:

Customer Service: USA: 1-800-541-8028

Visit www.flexco.com for other Flexco locations and products.

Please read this manual thoroughly and pass it on to any others who will be directly responsible for installation, operation and maintenance of this cleaner. While we have tried to make the installation and service tasks as easy and simple as possible, **it does however require correct installation and regular inspections and adjustments to maintain top working condition.**

1.2 User Benefits

Correct installation and regular maintenance will provide the following benefits for your operation:

- Reduced conveyor downtime
- Reduced man-hour labor
- Lower maintenance budget costs
- Increased service life for the belt cleaner and other conveyor components

1.3 Service Option

The MHS ESAC HD Secondary Cleaner is designed to be easily installed and serviced by your on-site personnel. However, if you would prefer complete turn-key factory service, please contact your local Flexco Field Representative.

Section 2 - Safety Considerations and Precautions

Before installing and operating the MHS ESAC HD Secondary Cleaner, it is important to review and understand the following safety information.

There are set-up, maintenance and operational activities involving both **stationary** and **operating** conveyors. Each case has a safety protocol.

2.1 Stationary Conveyors

The following activities are performed on stationary conveyors:

- Installation
- Tension adjustments
- Blade replacement
- Cleaning
- Repairs

DANGER

It is imperative that OSHA/MSHA Lockout/Tagout (LOTO) regulations, 9 CFR 1910.147, be followed before undertaking the preceding activities. Failure to use LOTO exposes workers to uncontrolled behavior of the belt cleaner caused by movement of the conveyor belt. Severe injury or death can result.

Before working:

- Lockout/Tagout the conveyor power source
- Disengage any takeups
- Clear the conveyor belt or clamp securely in place

WARNING

Use Personal Protective Equipment (PPE):

- Safety eyewear
- Hardhats
- Safety footwear

Close quarters, springs and heavy components create a worksite that compromises a worker's eyes, feet and skull. PPE must be worn to control the foreseeable hazards associated with conveyor belt cleaners. Serious injuries can be avoided.

2.2 Operating Conveyors

There are two routine tasks that must be performed while the conveyor is running:

- Inspection of the cleaning performance
- Dynamic troubleshooting

DANGER

Every belt cleaner is an in-running nip hazard. Never touch or prod an operating cleaner. Cleaner hazards cause instantaneous amputation and entrapment.

WARNING

Never adjust anything on an operating cleaner. Unforeseeable belt projections and tears can catch on cleaners and cause violent movements of the cleaner structure. Flailing hardware can cause serious injury or death.

WARNING

Belt cleaners can become projectile hazards. Stay as far from the cleaner as practical and use safety eyewear and headgear. Missiles can inflict serious injury.

Section 3 - Pre-installation Checks and Options

3.1 Checklist

- Check that the cleaner size is correct for the beltline width
- Check the belt cleaner carton and make sure all the parts are included
- Review the “Tools Needed” list on the top of the installation instructions
- Check the conveyor site:
 - Will the cleaner be installed on a chute
 - Is the install on an open head pulley requiring mounting structure (see 3.2 - Optional Installation Accessories)

Section 3 - Pre-installation Checks and Options

3.2 Optional Installation Accessories

Versatile, adjustable brackets that can be mounted on the conveyor structure so the MHS HD Secondary Cleaner can be quickly and easily bolted into place. Pole extenders are also available for wide, non-standard conveyor structures.

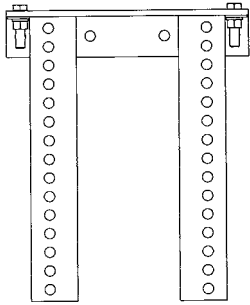

- 76071**
Standard Mounting Bracket Kit
- For most secondary cleaner installs.
 - 13" (325mm) W x 15 1/2" (388mm) L
 - Includes 2 brackets

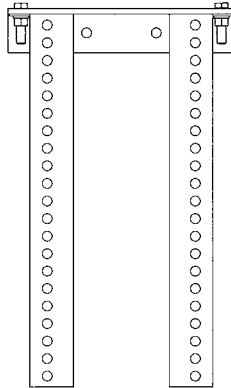

- 76072**
Long Mounting Bracket Kit
- For installations that require extra length legs.
 - 13" (325mm) W x 21 1/2" (538mm) L
 - Includes 2 brackets

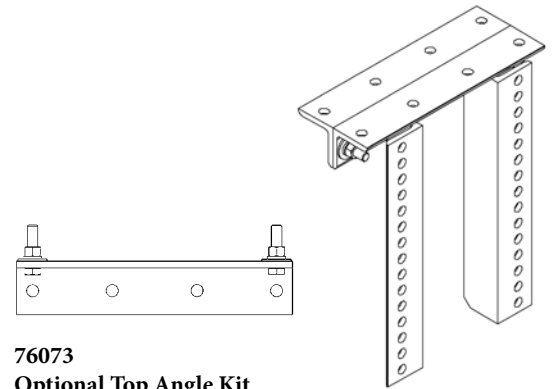

- 76073**
Optional Top Angle Kit
- Used with both standard and long mounting bracket kits for additional mounting options.
 - 13" (325mm) L
 - Includes 2 brackets

- 76024**
Pole Extender Kit
- Provides 30" (750mm) of extended pole length
 - Includes 2 pole extenders

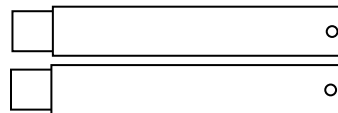

Optional Mounting Kits (includes 2 brackets/bars)			
Description	Ordering Number	Item Code	Wt. Lbs.
Standard Mounting Bracket Kit *	SSTSMB	76071	34.3
Long Mounting Bracket Kit *	SSTLMB	76072	43.5
Optional Top Angle Kit *	SSTOTA	76073	10.5
Pole Extender Kit	MAPEK	76024	21.9

*Hardware Included
 Lead time: 1 working day

Section 4.1 - Installation Instructions - Single Cartridge

MHS Enhanced Service Advantage Cartridge HD Secondary Belt Cleaner

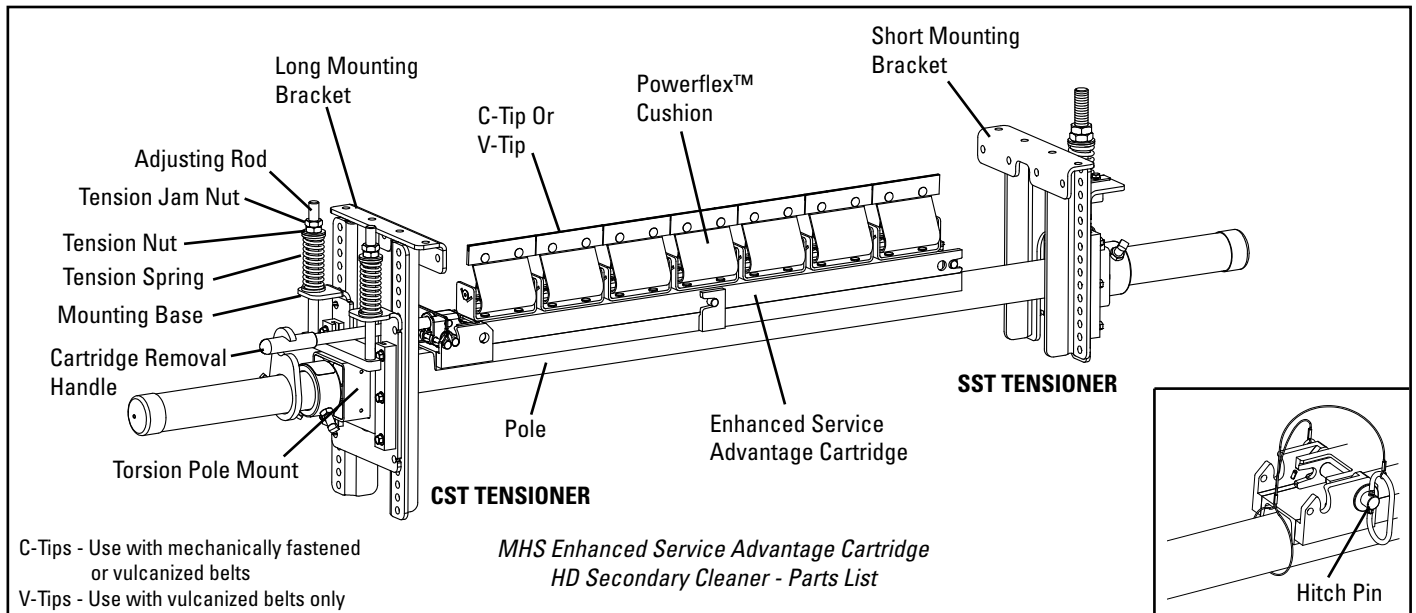

Physically lock out and tag the conveyor at the power source before you begin cleaner installation.

Optimal Mounting Locations

- A** At the Head Pulley
- B** At a Snub Pulley
- C** Before or After a Hold-down Roller

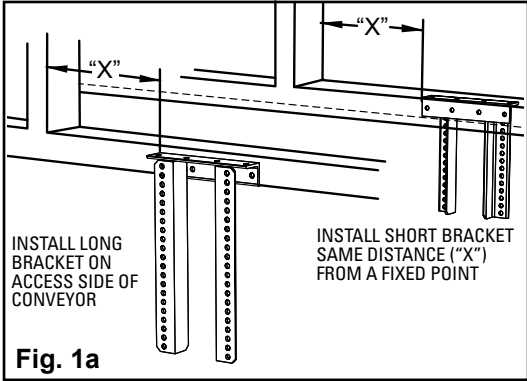
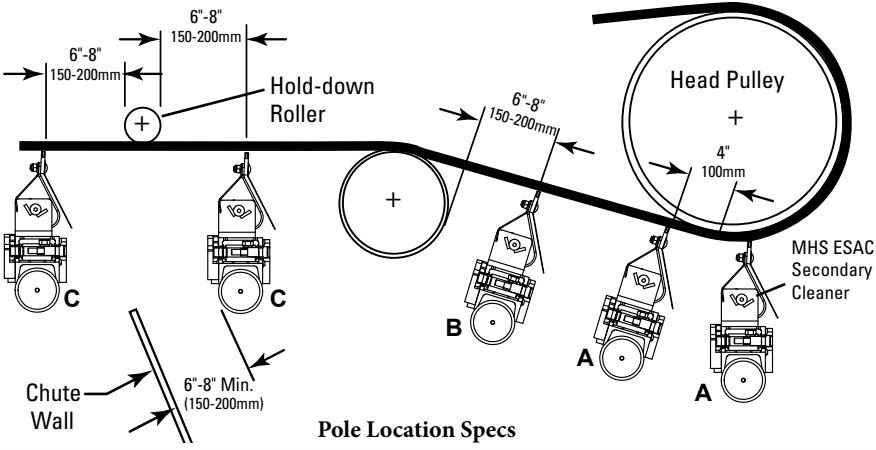

Fig. 1a

- 1a. **Install the mounting brackets.** Position the long mounting bracket on the structure on the side of the conveyor from which the cleaner will be installed and serviced. With the long bracket installed, take a measurement "X" from a fixed point on the structure to the mounting bracket and transfer to the opposite side of the structure; mount short mounting bracket in this location (Fig. 1a).
- 1b. **Transfer the belt location line to the mounting bracket.** Using a straight-edge pushed up to the bottom of the belt, mark the mounting bracket (Fig. 1b). Repeat on opposite side.

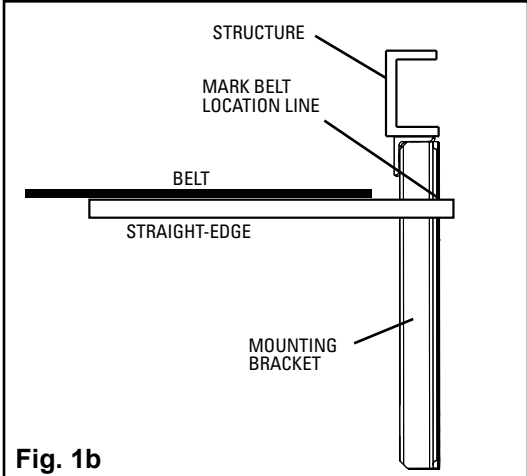
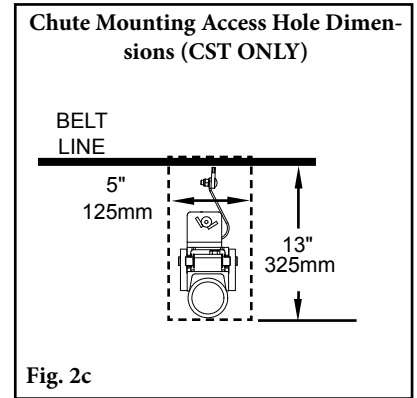
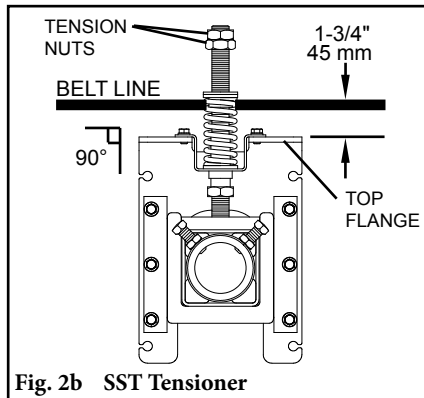
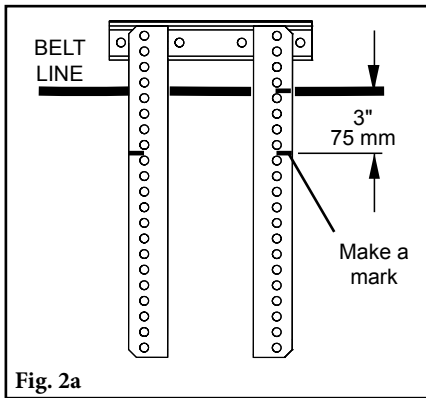

Fig. 1b

Section 4.1 - Installation Instructions - Single Cartridge

2. **Install the SST mounting base.** On the cartridge access (service) side of the conveyor, make a mark on the long bracket 3" (75mm) below the belt line (Fig. 2a); this will be needed in Step 3. On the opposite side, bolt the SST tensioner mounting base into position so the top flange of the base is 1-3/4" (45mm) below the belt line (Fig. 2b). Adjust the tension nut to the top of the adjusting rod.

NOTE: For chute mounting, a belt location line must be drawn on the chute wall so the mounting bases can be aligned with the belt. Cut an access hole as shown for the CST tensioner (Fig. 2c). Also cut an access hole as needed for the SST tensioner.



3. **Install the pole.** Remove the cartridge from the pole. Slide the pole into the SST torsion pole mount as far as needed. Then locate the other end into the CST tensioner torsion pole mount and attach the mounting base to the long bracket, aligning the flanges with the previously marked position (Fig. 3). Adjust tension nuts to the tops of the adjusting rods.

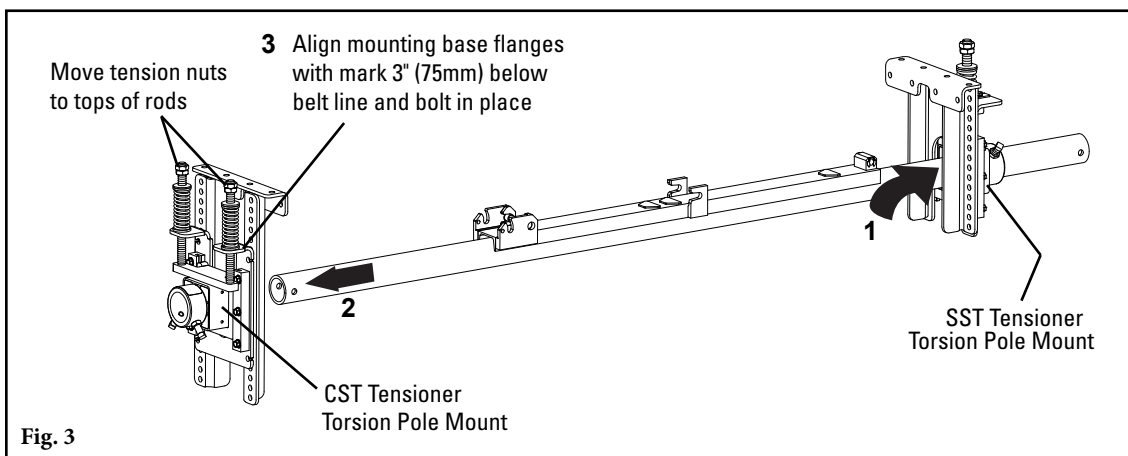

Section 4.1 - Installation Instructions - Single Cartridge

4. Different Cartridge Installation Methods.

Option A: Handle always on cartridge.

1. Slide the handle into the already installed knuckle, then tighten with supplied bolt/nut hardware.
2. Slide the cartridge onto the pole and lock down the knuckle onto the pole.
3. Slide the lock plate onto the pole, over the handle, then lock with the set screw.

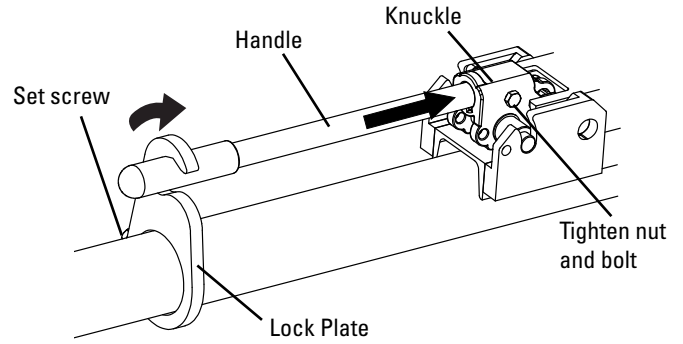

Option B: Handle stored inside pole.

1. Set the cartridge onto the pole, then slide the handle into the already installed knuckle.
2. Lock down the knuckle onto the pole, then remove handle and place into open pole end.
3. Using the lock pins provided, lock the knuckle and the handle in place.

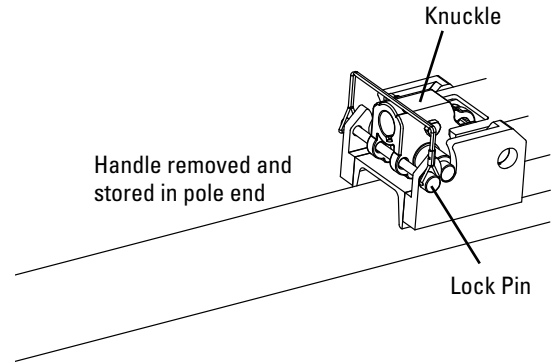

Option C: Hitch pin only.

1. To remove the knuckle assembly from the cartridge, flip cartridge upside down and use two 1/2" (13mm) wrenches to unlock knuckle pivot pins, then remove knuckle assembly.
2. Set the cartridge onto the pole.
3. Use rubber mallet (to prevent damage to the cartridge) to lock into place.
4. Using the hitch pin provided, lock the cartridge in place.

Use 2 wrenches to loosen pivot pins, then remove knuckle assy

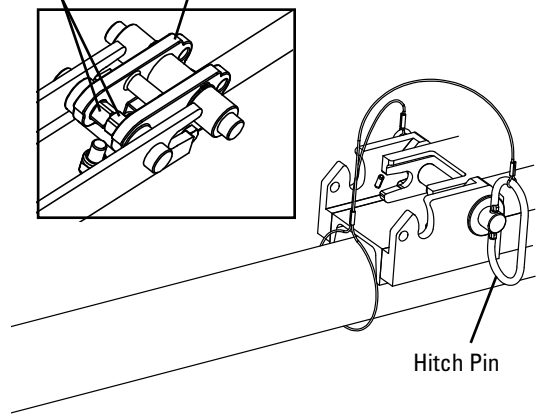

5. **Set the blade angle.** Center the pole/blades on the belt. Rotate the pole until the tips align with the white "MHS Standard" side of the tip setup gauge provided (Fig. 5a). Tighten the two locking bolts on each torsion pole mount to lock the pole in place (Fig. 5b). There should be no blade-to-belt contact while locking the pole in the correct position. If contact occurs, double check the dimension from Step 1.

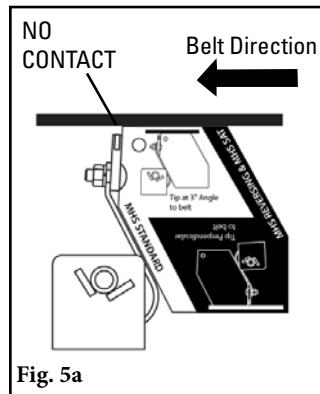

Fig. 5a

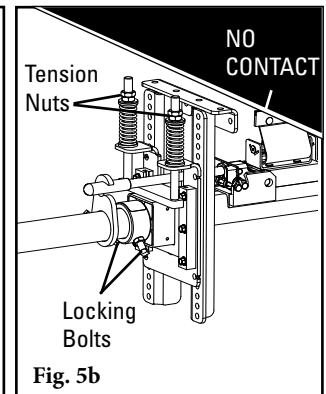
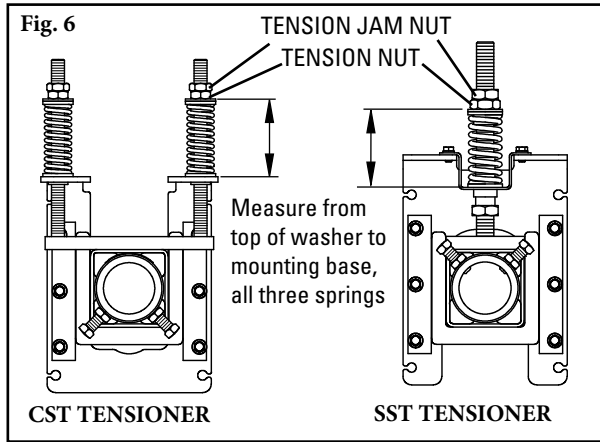

Fig. 5b

Section 4.1 - Installation Instructions - Single Cartridge



6. **Set the blade tension.** Loosen the top tension jam nuts on both sides. Tighten the tension nuts until the correct spring compression is reached (Fig. 6). Spring compression is determined by belt width. See chart below for the correct spring length for your belt width. Tighten top tension jam nuts.

Spring Length Chart
for SST Spring Tensioner

BLADE WIDTH	WHITE SPRING	SILVER SPRING	BLACK SPRING
24"	3 1/8"	3 7/8"	N/A
30"	2 7/8"	3 3/4"	N/A
36"	N/A	3 3/4"	3 7/8"
42"	N/A	3 5/8"	3 3/4"
48"	N/A	3 1/2"	3 5/8"
54"	N/A	3 3/8"	3 5/8"
60"	N/A	3 1/4"	3 1/2"
72"	N/A	N/A	3 3/8"

Shading indicates preferred spring option

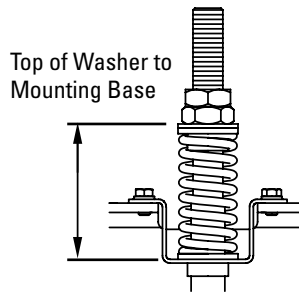

Spring Length Chart
for CST Spring Tensioner

BLADE WIDTH	WHITE SPRING	SILVER SPRING	BLACK SPRING	GOLD SPRING
24"	3 1/8"	3 7/8"	N/A	N/A
30"	2 7/8"	3 3/4"	N/A	N/A
36"	N/A	3 3/4"	3 7/8"	N/A
42"	N/A	3 5/8"	3 3/4"	N/A
48"	N/A	3 1/2"	3 5/8"	N/A
54"	N/A	3 3/8"	3 5/8"	N/A
60"	N/A	3 1/4"	3 1/2"	4"
72"	N/A	N/A	3 3/8"	4"
84"	N/A	N/A	3 1/8"	3 7/8"
96"	N/A	N/A	N/A	3 7/8"
120"	N/A	N/A	N/A	3 5/8"

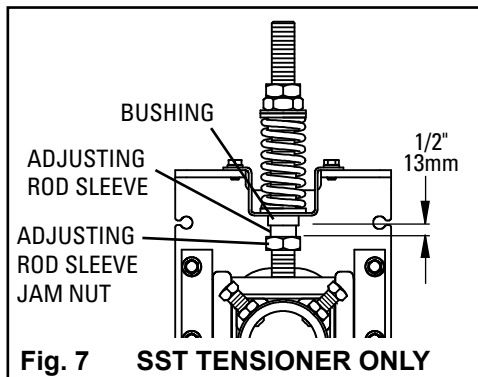
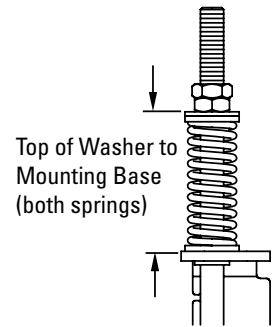

7. **Set adjusting rod sleeve (SST Tensioner only).** After setting the blade tension, screw the adjusting rod sleeve into the UHMW bushing until 1/2" (13mm) is showing (Fig. 7). Tighten the adjusting rod sleeve jam nut.

8. **IMPORTANT:** Apply the Spring Tension Labels to the conveyor structure for future blade retensioning.

9. **Test run the cleaner and inspect the cleaning performance.** If vibration occurs or more cleaning efficiency is desired, increase the blade tension by making 1/8" (3mm) compression adjustments on the tension springs.

SEE PAGE 16 FOR CARTRIDGE REPLACEMENT INSTRUCTIONS.

Section 4.2 - Installation Instructions - Dual Cartridge

MHS Enhanced Service Advantage Cartridge HD Secondary Belt Cleaner

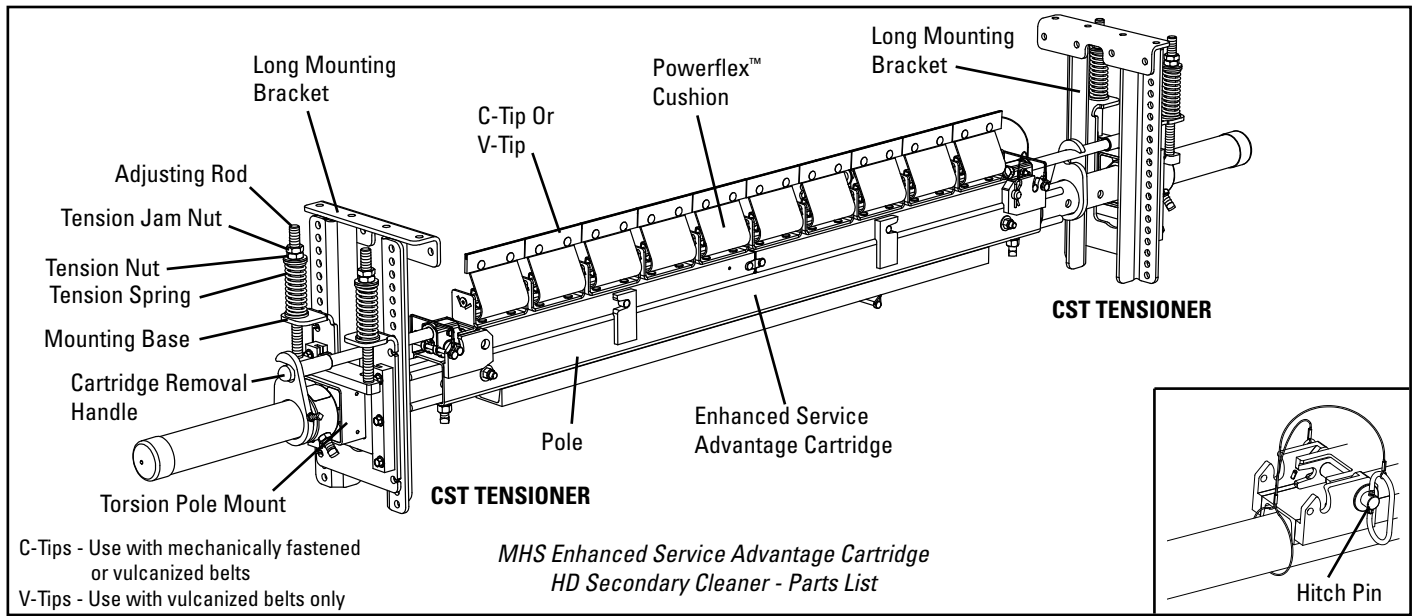

Physically lock out and tag the conveyor at the power source before you begin cleaner installation.

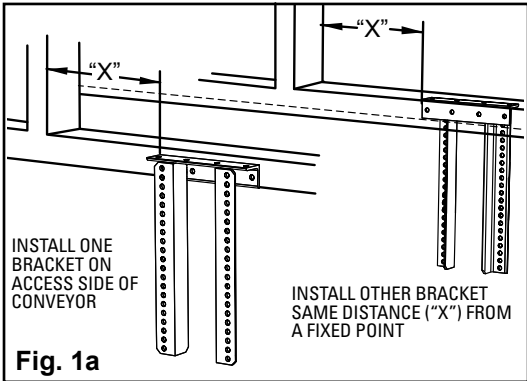
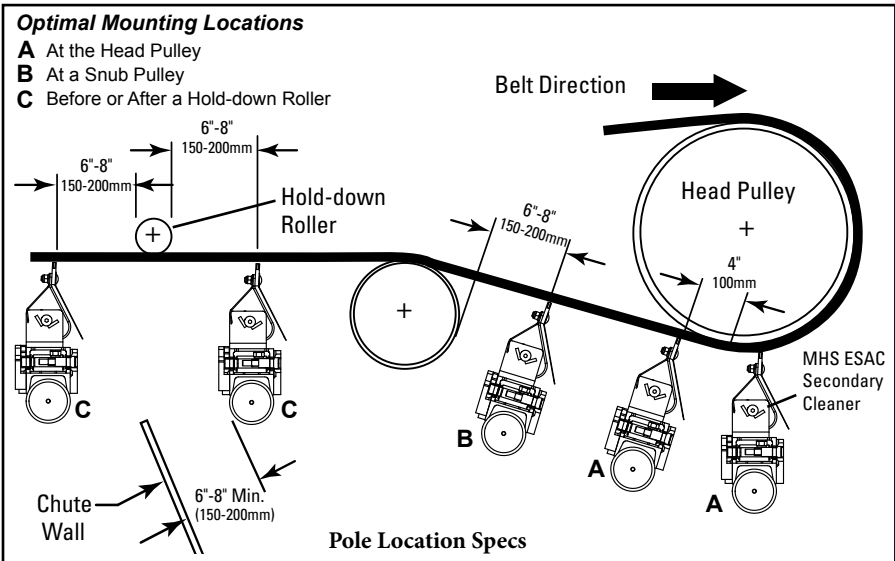

1a. **Install the mounting brackets.** Position one long mounting bracket on the structure on the side of the conveyor from which the cleaner will be installed and serviced. With the bracket installed, take a measurement "X" from a fixed point on the structure to the mounting bracket and transfer to the opposite side of the structure; mount the other mounting bracket in this location (Fig. 1a).

1b. **Transfer the belt location line to the mounting bracket.** Using a straight-edge pushed up to the bottom of the belt, mark the mounting bracket (Fig. 1b). Repeat on opposite side.

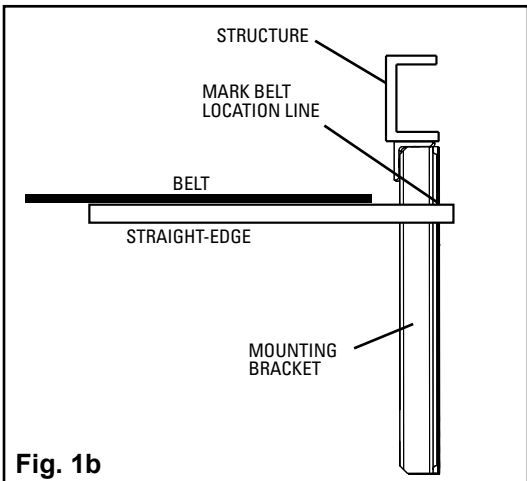

Section 4.2 - Installation Instructions - Dual Cartridge

2. **Install one CST mounting base.** On both sides of the conveyor, make a mark on the long brackets 3" (75mm) below the belt line (Fig. 2a); this will be needed in Step 3.

NOTE: For chute mounting, a belt location line must be drawn on the chute wall so the mounting bases can be aligned with the belt. Cut an access hole as shown for the CST tensioner (Fig. 2b).

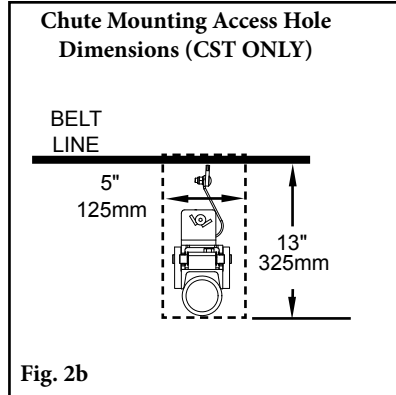
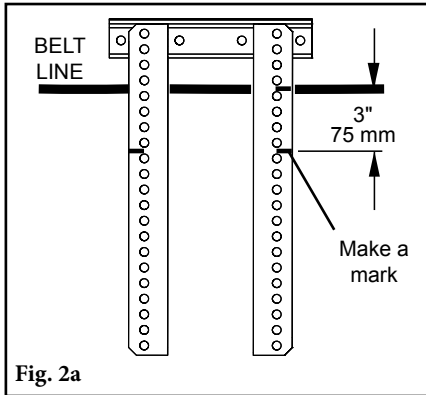

3. **Install the pole.** Remove the cartridges from the pole. Slide the pole into one CST torsion pole mount as far as needed. Then locate the other end into the other CST tensioner torsion pole mount and attach the mounting base to the long bracket, aligning the flanges with the previously marked position (Fig. 3). Adjust tension nuts to the tops of the adjusting rods.

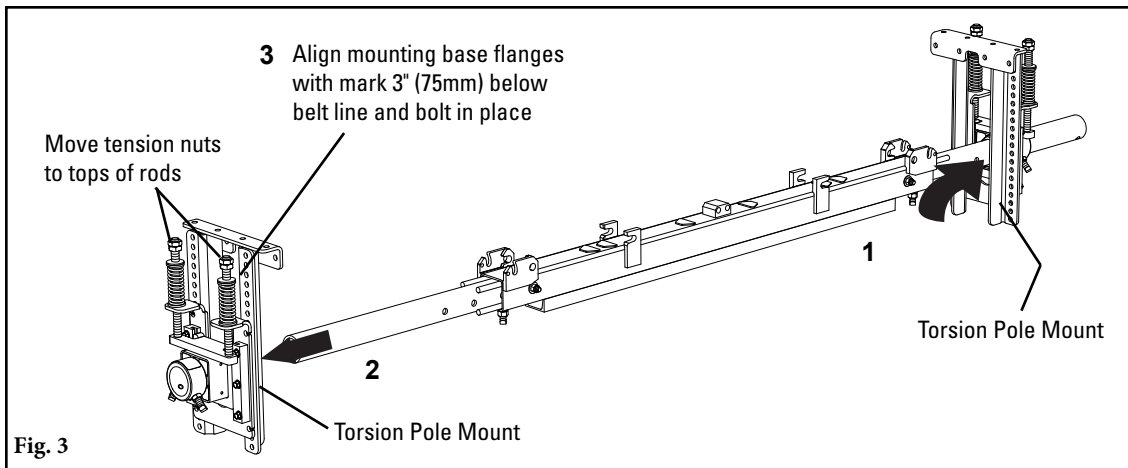

Section 4.2 - Installation Instructions - Dual Cartridge

4. Different Cartridge Installation Methods.

Option A: Handle always on cartridge.

1. Slide the handle into the already installed knuckle, then tighten with supplied bolt/nut hardware.
2. Slide the cartridge onto the pole and lock down the knuckle onto the pole.
3. Slide the lock plate onto the pole, over the handle, then lock with the set screw.
4. Repeat for other side.

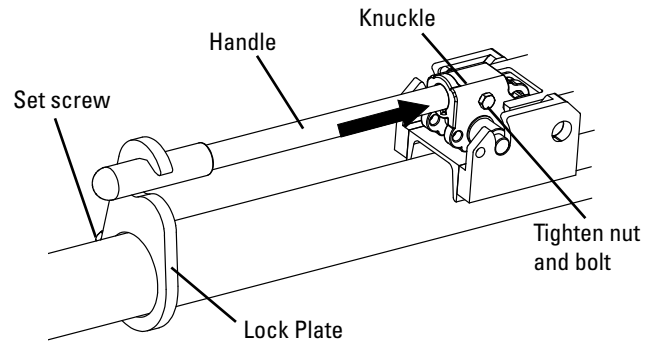

Option B: Handle stored inside pole.

1. Set the cartridge onto the pole, then slide the handle into the already installed knuckle.
2. Lock down the knuckle onto the pole, then remove handle and place into open pole end.
3. Using the lock pins provided, lock the knuckle and the handle in place.
4. Repeat for other side.

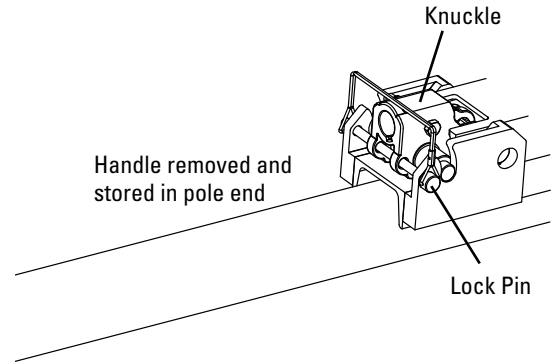

Option C: Hitch pin only.

1. To remove the knuckle assembly from the cartridge, flip cartridge upside down and use two 1/2" (13mm) wrenches to unlock knuckle pivot pins, then remove knuckle assy.
2. Set the cartridge onto the pole.
3. Use rubber mallet (to prevent damage to the cartridge) to lock into place.
4. Using the hitch pin provided, lock the cartridge in place.
5. Repeat for other side.

Use 2 wrenches to loosen pivot pins, then remove knuckle assy

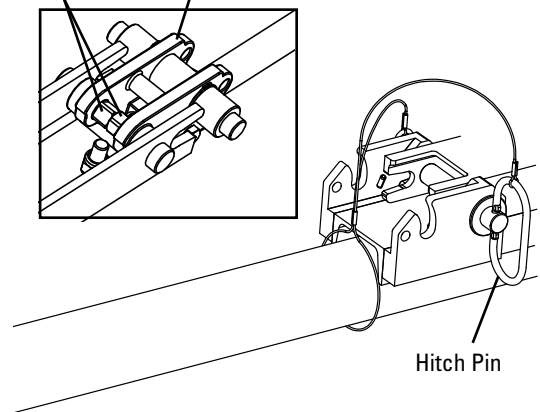

5. **Set the blade angle.** Center the pole/blades on the belt. Rotate the pole until the tips align with the white "MHS Standard" side of the tip setup gauge provided (Fig. 5a). Tighten the two locking bolts on each torsion pole mount to lock the pole in place (Fig. 5b). There should be no blade-to-belt contact while locking the pole in the correct position. If contact occurs, double check the dimension from Step 1.

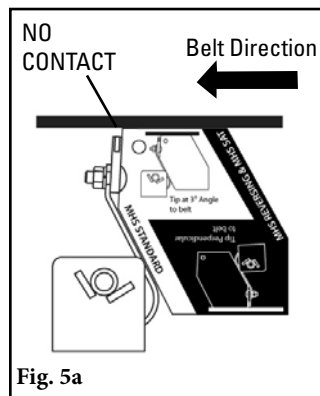

Fig. 5a

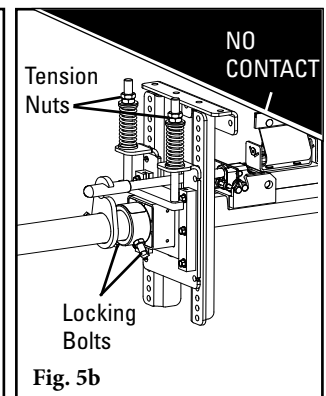
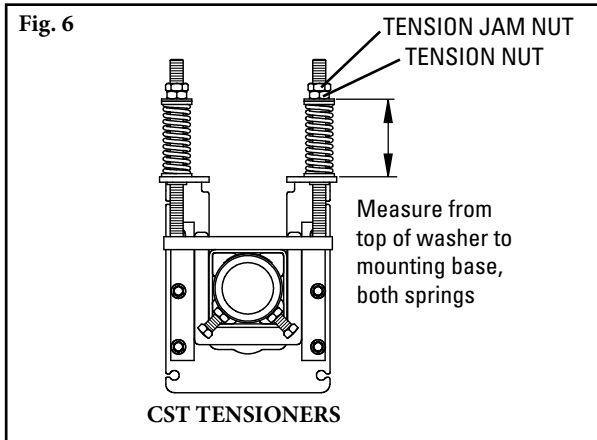

Fig. 5b

Section 4.2 - Installation Instructions - Dual Cartridge



- Set the blade tension. Loosen the top tension jam nuts on both sides. Tighten the tension nuts until the correct spring compression is reached (Fig. 6). Spring compression is determined by belt width. See chart below for the correct spring length for your belt width. Tighten top tension jam nuts.

Spring Length Chart
for CST Spring Tensioner

BLADE WIDTH	WHITE SPRING	SILVER SPRING	BLACK SPRING	GOLD SPRING
24"	3 1/8"	3 7/8"	N/A	N/A
30"	2 7/8"	3 3/4"	N/A	N/A
36"	N/A	3 3/4"	3 7/8"	N/A
42"	N/A	3 5/8"	3 3/4"	N/A
48"	N/A	3 1/2"	3 5/8"	N/A
54"	N/A	3 3/8"	3 5/8"	N/A
60"	N/A	3 1/4"	3 1/2"	4"
72"	N/A	N/A	3 3/8"	4"
84"	N/A	N/A	3 1/8"	3 7/8"
96"	N/A	N/A	N/A	3 7/8"
120"	N/A	N/A	N/A	3 5/8"

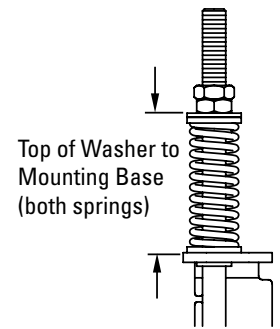

- IMPORTANT:** Apply the Spring Tension Labels to the conveyor structure for future blade retensioning.
- Test run the cleaner and inspect the cleaning performance. If vibration occurs or more cleaning efficiency is desired, increase the blade tension by making 1/8" (3mm) compression adjustments on the tension springs.

SEE NEXT PAGE FOR CARTRIDGE REPLACEMENT INSTRUCTIONS.

Section 4.3 - Cartridge Replacement Instructions

MHS Enhanced Service Advantage Cartridge HD Secondary Belt Cleaner

Physically lock out and tag the conveyor at the power source before you begin cleaner installation.

1. **Release tension on the cleaner.** Loosen both the tension jam nut and tension nut on all adjusting rods until the nuts are at the tops of the adjusting rods (Fig. 1).

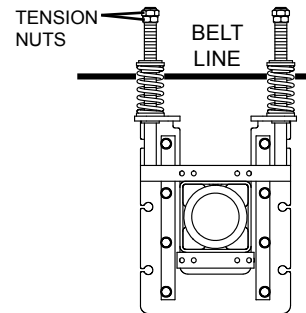

2. Different Cartridge Removal Methods.

Option A: Handle always on cartridge.

1. Loosen the lock plate set screw and disengage lock plate from handle.
2. Lift the handle to unlock the knuckle and cartridge, then pull cartridge out.
3. If using dual cartridge cleaner, repeat for other side.

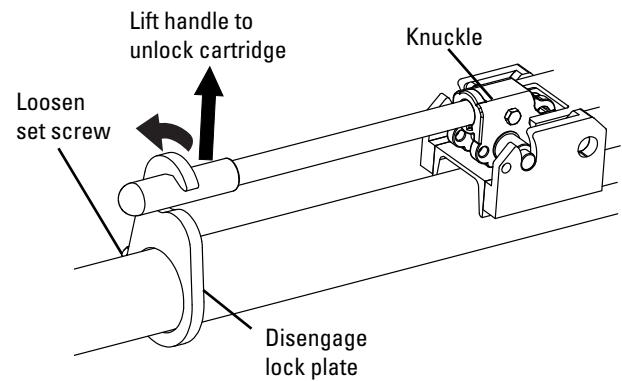

Option B: Handle stored inside pole.

1. Remove lock pins holding handle and knuckle in place.
2. Slide the handle into the knuckle and twist to lock.
3. Lift the handle to unlock the knuckle and cartridge, then pull cartridge out.
4. If using dual cartridge cleaner, repeat for other side.

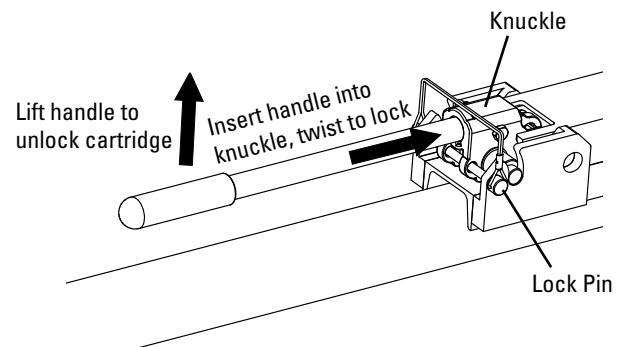

Option C: Hitch pin only.

1. Remove the hitch pin, then pull the cartridge out. Please note this method may require full access to the cleaner to loosen the cartridge.
2. If using dual cartridge cleaner, repeat for other side.

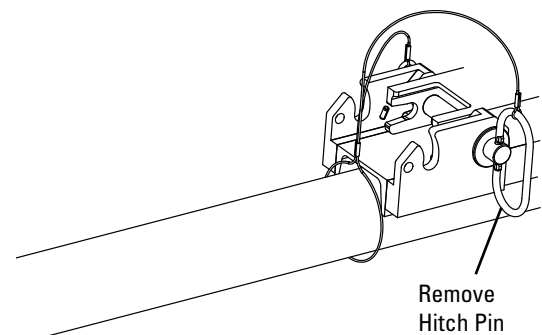

3. **Clean off pole.** Remove any debris that has built up on the pole.

Section 4.3 - Cartridge Replacement Instructions

4. **Replace the worn tips.** NOTE: If using a dual cartridge cleaner, please use the provided Cartridge Tip Alignment Tool to ensure the tips on both cartridges are located at the same height. It is recommended to use a second cartridge with new tips and cushions already installed for a quick change-out. However, new cleaner tips can be installed on the pulled cartridge on-site if needed.

Single Cartridge:

1. Remove all tips with hardware from the used cartridge.
2. Install all new tips and hardware without fully tightening.
3. Tighten one of the tips on one end of the cartridge.
4. Visually align all others while tightening remaining tips, ensuring a flat profile across all tips. Check with a straightedge. When finished, all tips should move freely without catching on the next tip and have no gaps larger than .030" (approximate thickness of a credit card).

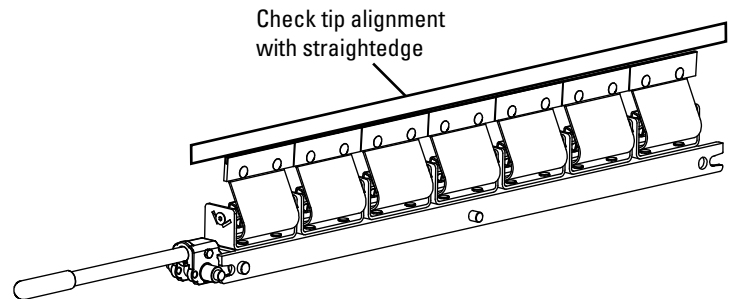

Dual Cartridge:

1. Remove all tips with hardware from the used cartridges.
2. Install all new tips and hardware without fully tightening.
3. On one cartridge, place the Cartridge Tip Alignment Tool on the end with the notch and alignment holes. Using those alignment holes, tighten the tool to the cartridge with wing nut (Fig. 1).
4. Set the tip height gauge on the Cartridge Tip Alignment Tool so that the loosely installed tip can push up into the corner of the tool (Fig. 2).
5. Tighten the first tip while holding it tight to the Cartridge Tip Alignment Tool (Fig. 2).
6. Visually align all others while tightening remaining tips, ensuring a flat profile across all tips. Check with a straightedge. When finished, all tips should move freely without catching on the next tip and have no gaps larger than .030" (approximate thickness of a credit card).
7. Repeat Steps 3, 5 and 6 for second cartridge, making sure to keep the tip height gauge locked in place so that both cartridges will be aligned when assembled to the pole.

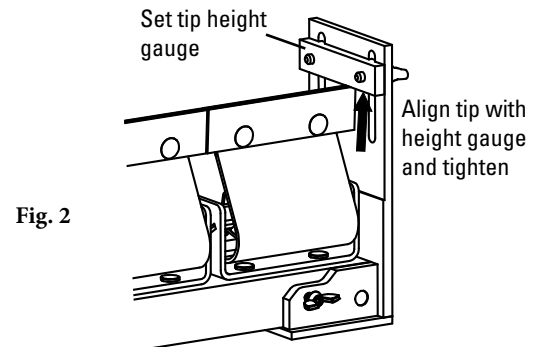
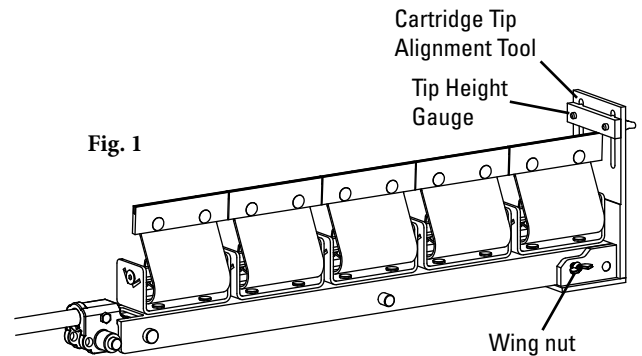

DO NOT RESET TIP HEIGHT GAUGE WHEN SWITCHING TO SECOND CARTRIDGE

Section 4.3 - Cartridge Replacement Instructions

5. Insert the reconditioned or replacement cartridge.

Option A: Handle always on cartridge.

1. Slide the cartridge onto the pole and lock down the knuckle onto the pole.
2. Slide the lock plate onto the pole, over the handle, then lock with the set screw.
3. If using dual cartridge, repeat for other side.

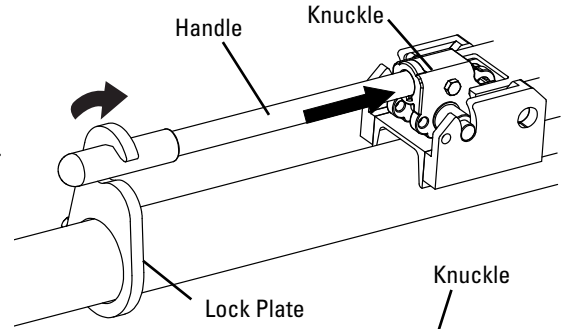

Option B: Handle stored inside pole.

1. Set the cartridge onto the pole, then slide the handle into the already installed knuckle.
2. Lock down the knuckle onto the pole, then remove handle and place into open pole end.
3. Using the lock pins provided, lock the knuckle and the handle in place.
4. If using dual cartridge, repeat for other side.

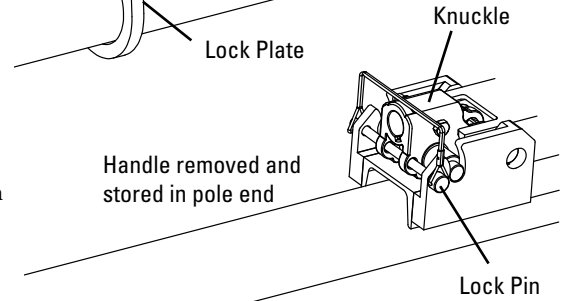

Option C: Hitch pin only.

1. Set the cartridge onto the pole.
2. Use hammer and buffer material (to prevent damage to the cartridge) to lock into place.
3. Using the hitch pin provided, lock the cartridge in place.
4. If using dual cartridge, repeat for other side.

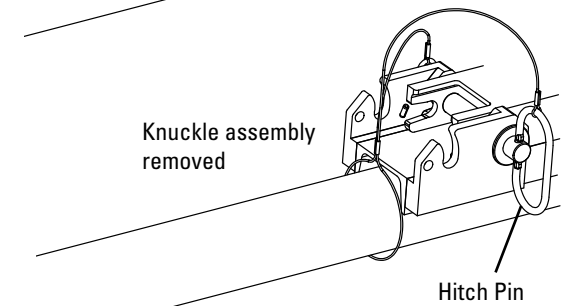

6. Retension the cleaner tips to the belt. Turn the tension nuts until the correct spring length is reached for your blade width. See Spring Length Charts at right (or on the cleaner).

Spring Length Chart for SST Spring Tensioner

BLADE WIDTH	WHITE SPRING	SILVER SPRING	BLACK SPRING
24"	3 1/8"	3 7/8"	N/A
30"	2 7/8"	3 3/4"	N/A
36"	N/A	3 3/4"	3 7/8"
42"	N/A	3 5/8"	3 3/4"
48"	N/A	3 1/2"	3 5/8"
54"	N/A	3 3/8"	3 5/8"
60"	N/A	3 1/4"	3 1/2"
72"	N/A	N/A	3 3/8"

Shading indicates preferred spring option

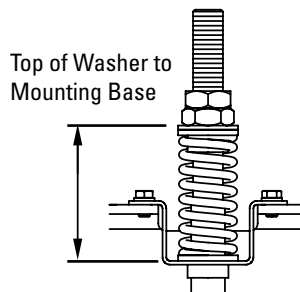

Spring Length Chart for CST Spring Tensioner

for CST Spring Tensioner

BLADE WIDTH	WHITE SPRING	SILVER SPRING	BLACK SPRING	GOLD SPRING
24"	3 1/8"	3 7/8"	N/A	N/A
30"	2 7/8"	3 3/4"	N/A	N/A
36"	N/A	3 3/4"	3 7/8"	N/A
42"	N/A	3 5/8"	3 3/4"	N/A
48"	N/A	3 1/2"	3 5/8"	N/A
54"	N/A	3 3/8"	3 5/8"	N/A
60"	N/A	3 1/4"	3 1/2"	4"
72"	N/A	N/A	3 3/8"	4"
84"	N/A	N/A	3 1/8"	3 7/8"
96"	N/A	N/A	N/A	3 7/8"
120"	N/A	N/A	N/A	3 5/8"

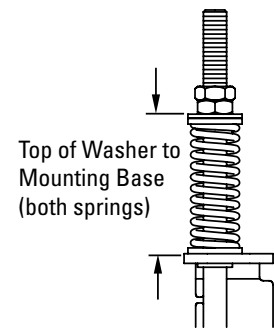

7. Test run the cleaner and inspect the cleaning performance. If vibration occurs or more cleaning efficiency is desired, increase the blade tension by making 1/2" (3mm) compression adjustments on the tension springs.

Section 4.4 - Push-up Tensioning Instructions

For SST Tensioner/Single-Side Access Only

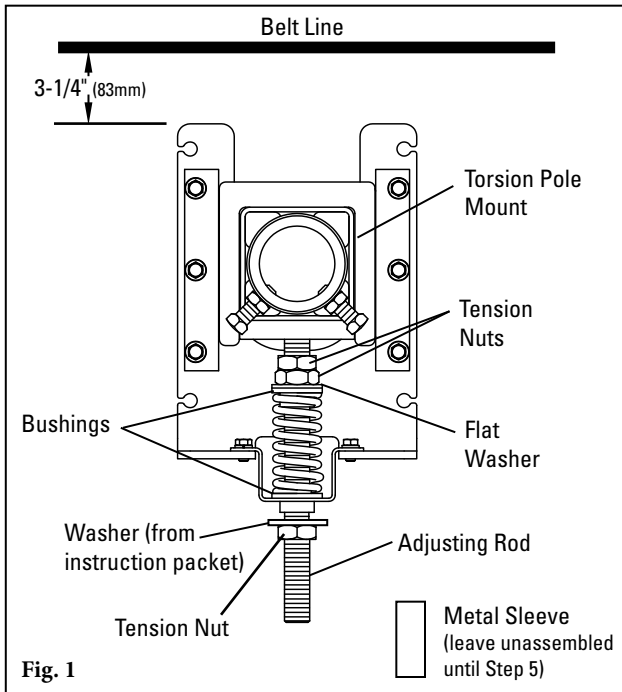

- 1. Reconfigure the standard pull-up tensioner to the push-up style.** Remove the 3 tension nuts, the flat washer, 2 bushings, the spring, the sleeve and the hat bracket; reassemble (Fig. 1) with 2 tension nuts, the flat washer, 2 bushings, the spring and the hat bracket on the upper end of the adjusting rod. Add washer (from instruction packet) and 3rd tension nut to bottom of adjusting rod.
- 2. Install the tensioner mounting bases.** Mount the bases to the structure or chute so that the tops of the base legs are 3-1/4" (83mm) below the belt (Fig. 1).

- 3. Install the cleaner pole and set the blade angle.** Follow the installation steps from the cleaner instructions on Page 8. **Note:** be sure the lock bolts on the torsion pole mount have been securely tightened to lock the pole in place before moving to Step 4.

- 4. Set the blade tension.** Remove the bottom tension nut and washer from the adjusting rod. Turn the 2 upper tension nuts until the spring is compressed to the length shown on the Spring Length Chart at right. Tighten the 2 tension nuts together to prevent loosening.

Spring Length Chart for SST Spring Tensioner

BLADE WIDTH	WHITE SPRING	SILVER SPRING	BLACK SPRING
24"	3 1/8"	3 7/8"	N/A
30"	2 7/8"	3 3/4"	N/A
36"	N/A	3 3/4"	3 7/8"
42"	N/A	3 5/8"	3 3/4"
48"	N/A	3 1/2"	3 5/8"
54"	N/A	3 3/8"	3 5/8"
60"	N/A	3 1/4"	3 1/2"
72"	N/A	N/A	3 3/8"

Shading indicates preferred spring option

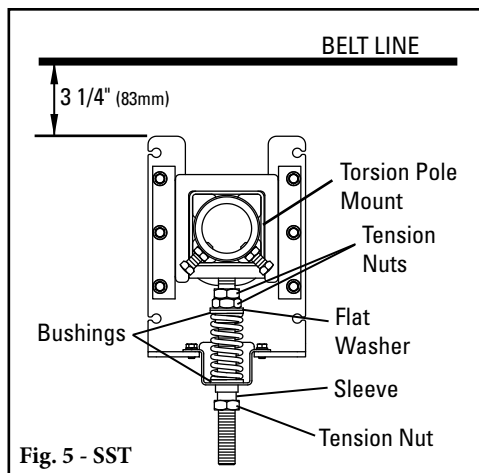
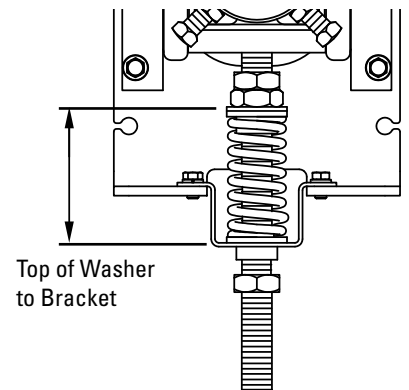

- 5. Replace the sleeve.** Position the sleeve over the adjusting rod and turn it until it is in the middle of the bushing. Replace the bottom tension nut and tighten until it locks the sleeve in place (Fig. 5).

Section 5 - Pre-Operation Checklist and Testing

5.1 Pre-Op Checklist

- Recheck that all fasteners are tightened properly
- Add pole caps
- Apply all supplied labels to the cleaner
- Check the blade location on the belt
- Be sure that all installation materials and tools have been removed from the belt and the conveyor area

5.2 Test Run the Conveyor

- Run the conveyor for at least 15 minutes and inspect the cleaning performance
- Check the tensioner spring for recommended length (proper tensioning)
- Make adjustments as necessary

NOTE: Observing the cleaner when it is running and performing properly will help to detect problems or when adjustments are needed later.

Section 6 - Maintenance

Flexco belt cleaners are designed to operate with minimum maintenance. However, to maintain superior performance some service is required. When the cleaner is installed a regular maintenance program should be set up. This program will ensure that the cleaner operates at optimal efficiency and problems can be identified and fixed before the cleaner stops working.

All safety procedures for inspection of equipment (stationary or operating) must be observed. The MHS ESAC HD Belt Cleaner operates at the discharge end of the conveyor and is in direct contact with the moving belt. Only visual observations can be made while the belt is running. Service tasks can be done only with the conveyor stopped and by observing the correct lockout/tagout procedures.

6.1 New Installation Inspection

After the new cleaner has run for a few days a visual inspection should be made to ensure the cleaner is performing properly. Make adjustments as needed.

6.2 Routine Visual Inspection (every 2-4 weeks)

A visual inspection of the cleaner and belt should look for:

- If spring length is the correct length for optimal tensioning
- If belt looks clean or if there are areas that are dirty
- If blade is worn out and needs to be replaced
- If there is damage to the blade or other cleaner components
- If fugitive material is built up on cleaner or in the transfer area
- If there is cover damage to the belt
- If there is vibration or bouncing of the cleaner on the belt
- If a snub pulley is used, a check should be made for material buildup on the pulley
- Significant signs of carryback

If any of the above conditions exist, a determination should be made on when the conveyor can be stopped for cleaner maintenance.

6.3 Routine Physical Inspection (every 6-8 weeks)

When the conveyor is not in operation and properly locked and tagged out, a physical inspection of the cleaner to perform the following tasks:

- Clean material buildup off of the cleaner blade and pole
- Closely inspect the blade for wear and any damage. Replace if needed.
- Ensure full blade to belt contact
- Inspect the cleaner pole for damage
- Inspect all fasteners for tightness and wear. Tighten or replace as needed.
- Replace any worn or damaged components
- Check the tension of the cleaner blade to the belt. Adjust the tension if necessary using the chart on the cleaner or the ones on Page 11.
- When maintenance tasks are completed, test run the conveyor to ensure the cleaner is performing properly

Section 6 - Maintenance

6.4 Maintenance Log

Conveyor Name/No. _____

Date: _____ Work done by: _____ Service Quote # _____

Activity: _____

Date: _____ Work done by: _____ Service Quote # _____

Activity: _____

Date: _____ Work done by: _____ Service Quote # _____

Activity: _____

Date: _____ Work done by: _____ Service Quote # _____

Activity: _____

Date: _____ Work done by: _____ Service Quote # _____

Activity: _____

Date: _____ Work done by: _____ Service Quote # _____

Activity: _____

Date: _____ Work done by: _____ Service Quote # _____

Activity: _____

Section 6 - Maintenance

6.5 Cleaner Maintenance Checklist

Belt Cleaner: _____ Serial Number: _____

Beltline Information:

Beltline Number: _____ Belt Condition: _____

Belt Width: 24" 30" 36" 42" 48" 54" 60" 72" 84" 96" 120"
(600mm) (750mm) (900mm) (1050mm) (1200mm) (1350mm) (1500mm) (1800mm) (2100mm) (2400mm) (3000mm)

Belt Speed: _____ fpm Belt Thickness: _____

Belt Splice _____ Condition of Splice _____ Number of splices _____ Skived Unskived

Material conveyed _____

Days per week run _____ Hours per day run _____

Blade Life:

Date blades installed: _____ Date blades inspected: _____ Estimated blade life: _____

Are blades making complete contact with belt? Yes No

Blade wear: LEFT _____ MIDDLE _____ RIGHT _____

Blade condition: Good Grooved Smiled Not contacting belt Damaged

Measurement of spring: Required _____ Currently _____

Was Cleaner Adjusted: Yes No

Pole Condition: Good Bent Worn

Lagging: Slide lag Ceramic Rubber Other None

Condition of lagging: Good Bad Other _____

Cleaner's Overall Performance: (Rate the following 1 - 5, 1 = very poor - 5 = very good)

Appearance: Comments: _____

Location: Comments: _____

Maintenance: Comments: _____

Performance: Comments: _____

Other Comments: _____

Section 7 - Troubleshooting

Problem	Possible Cause	Possible Solutions
Vibration	Cleaner secure bolts not set	Ensure all locking nuts are tight (Loctite)
	Cleaner not set up correctly	Ensure cleaner set up properly (check tip angle with gauge)
	Belt tension too high	Ensure cleaner can conform to belt, or replace with alternate Flexco secondary cleaner
	Belt flap	Introduce hold-down roller to flatten belt
	Cleaner over-tensioned	Ensure cleaner is correctly tensioned
	Cleaner under-tensioned	Ensure cleaner is correctly tensioned
Material buildup on cleaner	Cleaner not set up correctly	Ensure cleaner set up properly (1°-3° into belt)
	Buildup on chute	Ensure cleaner is not located too close to back of chute, allowing buildup
	Cleaner being overburdened	Introduce Flexco precleaner
	Excessive sticky material	Frequently clean unit of buildup
Damaged belt cover	Cleaner over-tensioned	Ensure cleaner is correctly tensioned
	Cleaner blade damage	Check blade for wear, damage and chips, replace where necessary
	Attack angle not correct	Ensure cleaner set up properly (check tip angle with gauge)
	Material buildup in chute	Frequently clean unit of buildup
Cleaner not conforming to belt	Cleaner not set up correctly	Ensure cleaner set up properly (check tip angle with gauge)
	Belt tension too high	Ensure cleaner can conform to belt (introduce hold-down roller), or replace with alternate Flexco secondary cleaner
	Belt flap	Introduce hold-down roller to flatten belt
	Cleaner cannot conform	Ensure cleaner can conform to belt (introduce hold-down roller), or replace with alternate Flexco secondary cleaner
Material passing cleaner	Cleaner not set up correctly	Ensure cleaner set up properly (check tip angle with gauge)
	Cleaner tension too low	Ensure cleaner is correctly tensioned
	Cleaner blades worn/damaged	Check blades for wear, damage and chips, replace where necessary
	Cleaner being overburdened	Introduce Flexco precleaner
	Belt flap	Introduce hold-down roller to flatten belt
	Belt worn or grooved	Introduce water spray pole
	Cleaner cannot conform	Ensure cleaner can conform to belt (introduce hold-down roller), or replace with alternate Flexco secondary cleaner
Damage to mechanical fastener	Incorrect cleaner blade selection	Change blade type to accommodate fastener style (C-Tip or V-Tip)
	Belt not skived correctly	Spot and redo splice correctly, lowering the profile flush or below belt surface
	Blade angle incorrect	Reset with gauge
Missing material in belt center only	Cupped Belt	Install hold-down roller and reset blade angle with gauge
	Cleaner blade worn/damaged	Check blade for wear, damage and chips, replace where necessary
Missing material on outer edges only	Cupped Belt	Install hold-down roller and reset blade angle with gauge
	Cleaner blade worn/damaged	Check blade for wear, damage and chips, replace where necessary

Section 8 - Specs and CAD Drawings

8.1 Specs and Guidelines

Pole Length Specifications*								
VERSION	CLEANER SIZE		BLADE WIDTH		POLE LENGTH		MAXIMUM CONVEYOR SPAN	
	in.	mm	in.	mm	in.	mm	in.	mm
Single	24	600	24	600	78	1950	66	1650
	30	750	30	750	84	2100	72	1800
	36	900	36	900	90	2250	78	1950
	42	1050	42	1050	96	2400	84	2100
	48	1200	48	1200	102	2550	90	2250
	54	1350	54	1350	108	2700	96	2400
	60	1500	60	1500	114	2850	102	2550
Dual	60	1500	60	1500	120	3000	108	2700
	72	1800	72	1800	132	3300	120	3000
	84	2100	84	2100	144	3600	132	3300
	96	2400	96	2400	156	3900	144	3600
	120	3000	120	3000	180	4500	168	4200

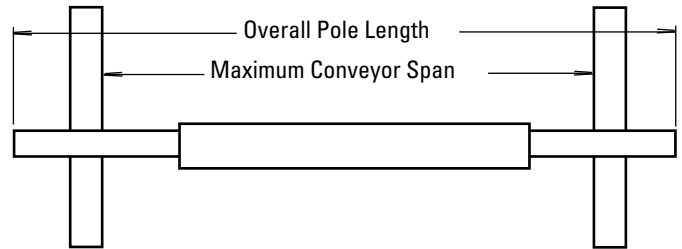

*For special extra long pole length requirements a Pole Extender Kit (#76024) is available that provides 30" (750mm) of extended pole length. Pole Diameter - 2-7/8" (73mm)

Clearance Guidelines for Installation				
VERSION	HORIZONTAL CLEARANCE REQUIRED		VERTICAL CLEARANCE REQUIRED	
	in.	mm	in.	mm
Single	4-1/2	114	11	279
Dual	4-1/2	114	12-1/2	318

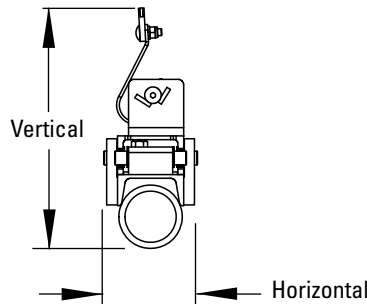

Aluminum Content		
ALUMINUM ALLOY TYPE	PERCENT	
	Mg Magnesium	Ti Titanium
6061	1.0%	0.0%

Spring Length Chart for SST Spring Tensioner

BLADE WIDTH	WHITE SPRING	SILVER SPRING	BLACK SPRING
24"	3 1/8"	3 7/8"	N/A
30"	2 7/8"	3 3/4"	N/A
36"	N/A	3 3/4"	3 7/8"
42"	N/A	3 5/8"	3 3/4"
48"	N/A	3 1/2"	3 5/8"
54"	N/A	3 3/8"	3 5/8"
60"	N/A	3 1/4"	3 1/2"
72"	N/A	N/A	3 3/8"

Shading indicates preferred spring option

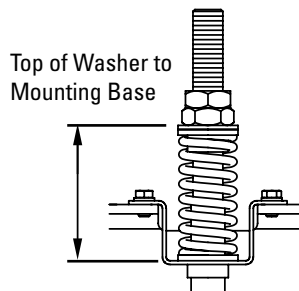

Spring Length Chart for CST Spring Tensioner

BLADE WIDTH	WHITE SPRING	SILVER SPRING	BLACK SPRING	GOLD SPRING
24"	3 1/8"	3 7/8"	N/A	N/A
30"	2 7/8"	3 3/4"	N/A	N/A
36"	N/A	3 3/4"	3 7/8"	N/A
42"	N/A	3 5/8"	3 3/4"	N/A
48"	N/A	3 1/2"	3 5/8"	N/A
54"	N/A	3 3/8"	3 5/8"	N/A
60"	N/A	3 1/4"	3 1/2"	4"
72"	N/A	N/A	3 3/8"	4"
84"	N/A	N/A	3 1/8"	3 7/8"
96"	N/A	N/A	N/A	3 7/8"
120"	N/A	N/A	N/A	3 5/8"

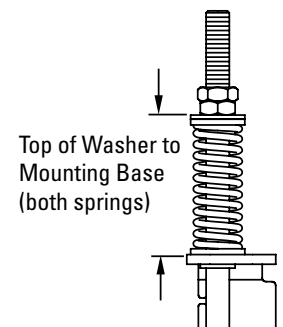

Specifications:

- Maximum Belt Speed 1200 FPM (6M/sec)
- Temperature Rating -30°F to 180°F (-35°C to 82°C)
- Usable Blade Wear Length 3/8" (9mm)
- Blade Materials..... C-Tip: Impact Resistant Tungsten Carbide (works with mechanical fasteners)
V-Tip: Long Life Tungsten Carbide (for vulcanized belts only)
- Available for Belt Widths..... 24" to 120" (600 to 3000 mm). Other sizes available upon request.

Patent Pending

Section 8 - Specs and CAD Drawings

8.2 CAD Drawing - MHS ESAC with C-Tips - Single Cartridge

SPECIFICATIONS				SAC MHS C CLEANER		SA CARTRIDGE POLE		SA CARTRIDGE	
BELT WIDTH 'A' (in)	BELT WIDTH 'A' (mm)	POLE LENGTH 'B' (in)	POLE LENGTH 'B' (mm)	ORDER NUMBER	ITEM CODE	ORDER NUMBER	ITEM CODE	ORDER NUMBER	ITEM CODE
24	600	78	1981	MHS-24-ESAC	77840	SACPL-24/600	77887	CART-24/600	77900
30	700	84	2133	MHS-30-ESAC	77841	SACPL-30/750	77888	CART-30/750	77901
36	900	90	2286	MHS-36-ESAC	77842	SACPL-36/900	77889	CART-36/900	77902
42	1050	96	2438	MHS-42-ESAC	77843	SACPL-42/1050	77890	CART-42/1050	77903
48	1200	102	2590	MHS-48-ESAC	77844	SACPL-48/1200	77891	CART-48/1200	77904
54	1350	108	2743	MHS-54-ESAC	77845	SACPL-54/1350	77892	CART-54/1350	77905
60	1500	114	2895	MHS-60-ESAC	77846	SACPL-60/1500	77893	CART-60/1500	77906
72	1800	126	3200	MHS-72-ESAC	77847	SACPL-72/1800	77894	CART-72/1800	77907

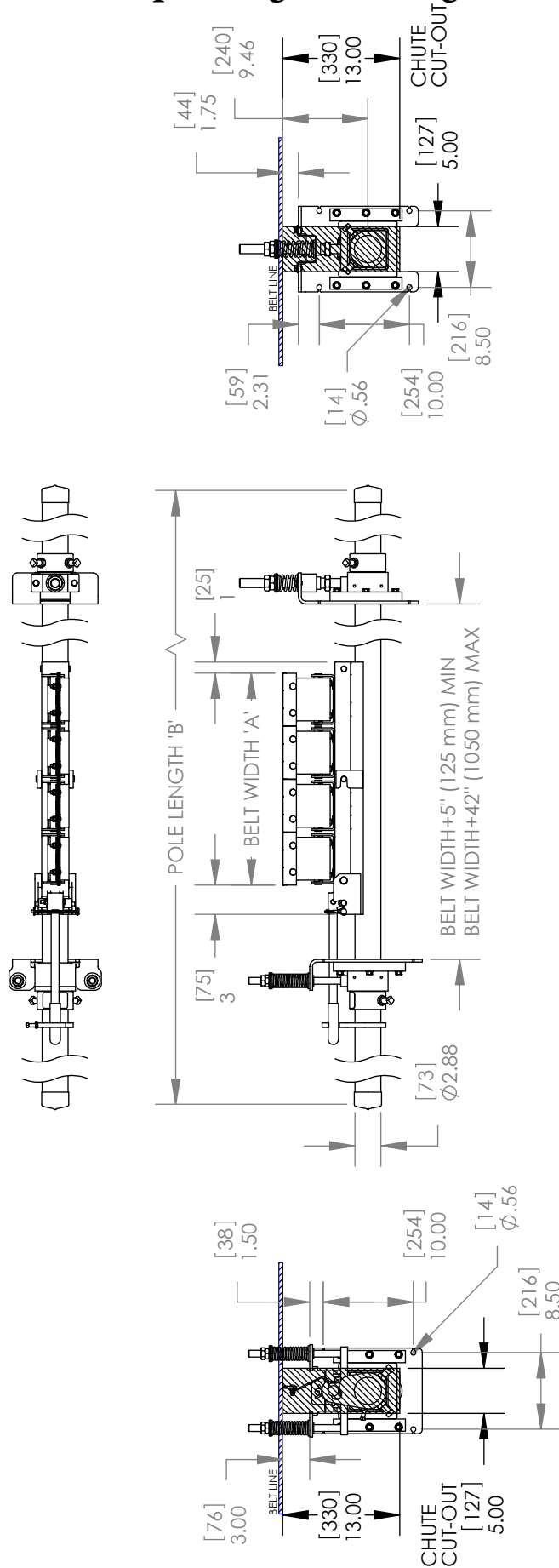

Section 8 - Specs and CAD Drawings

8.2 CAD Drawing - MHS ESAC with V-Tips - Single Cartridge

SPECIFICATIONS			SAC MHS V CLEANER		SA CARTRIDGE POLE		SA CARTRIDGE	
BELT WIDTH 'A' (in)	POLE LENGTH 'B' (in)	# OF BLADES	ORDER NUMBER	ITEM CODE	ORDER NUMBER	ITEM CODE	ORDER NUMBER	ITEM CODE
24	78	4	MHS-24V-ESAC	77853	SACPL-24/600	77887	CART-24/600	77900
30	84	5	MHS-30V-ESAC	77854	SACPL-30/750	77888	CART-30/750	77901
36	90	6	MHS-36V-ESAC	77855	SACPL-36/900	77889	CART-36/900	77902
42	96	7	MHS-42V-ESAC	77856	SACPL-42/1050	77890	CART-42/1050	77903
48	102	8	MHS-48V-ESAC	77857	SACPL-48/1200	77891	CART-48/1200	77904
54	108	9	MHS-54V-ESAC	77858	SACPL-54/1350	77892	CART-54/1350	77905
60	114	10	MHS-60V-ESAC	77859	SACPL-60/1500	77893	CART-60/1500	77906
72	126	12	MHS-72V-ESAC	77860	SACPL-72/1800	77894	CART-72/1800	77907

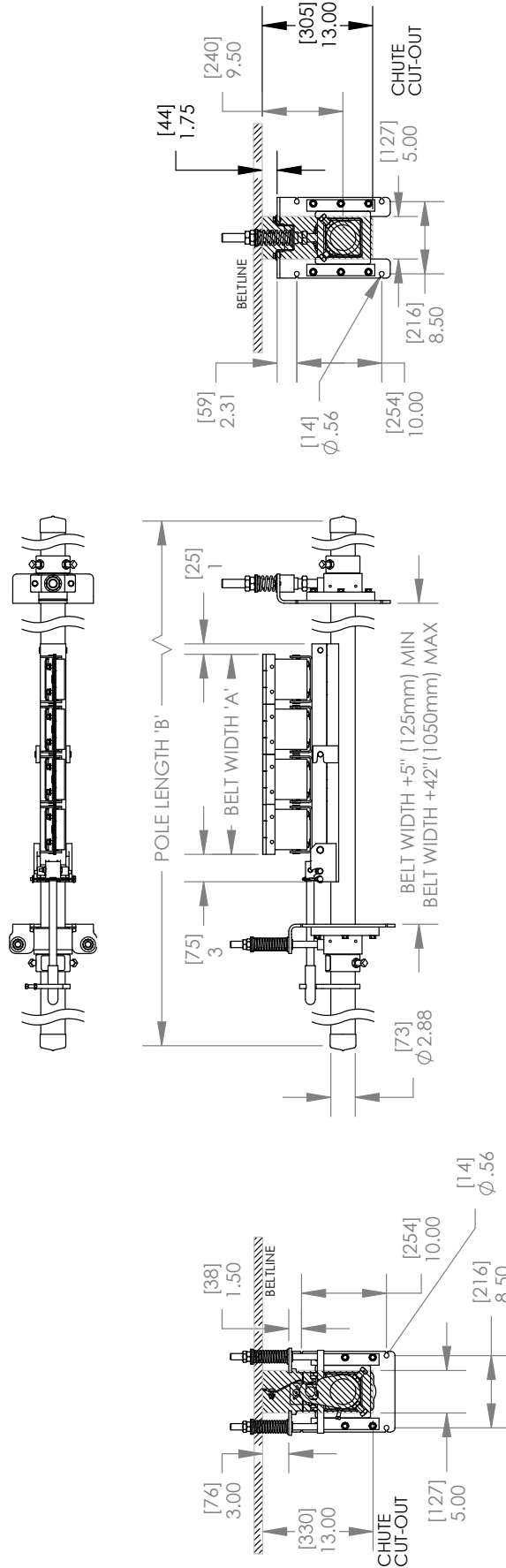

Section 8 - Specs and CAD Drawings

8.2 CAD Drawing - MHS ESAC with C-Tips - Dual Cartridge

SPECIFICATIONS			SAC MHS C CLEANER		SAC CENTER POLE		SA CARTRIDGE SET	
BELT WIDTH 'A' (in)	MAX POLE LENGTH 'B' (in)	# OF BLADES	ORDER NUMBER	ITEM CODE	ORDER NUMBER	ITEM CODE	ORDER NUMBER	ITEM CODE
60	120	10	MHS-60-E2SAC	77848	SACPL2-60/1500	77895	CART2-60/1500	77908
72	132	12	MHS-72-E2SAC	77849	SACPL-72/1800	77896	CART2-72/1800	77909
84	144	14	MHS-84-E2SAC	77850	SACPL-84/2100	77897	CART2-84/2100	77910
96	156	16	MHS-96-E2SAC	77851	SACPL-96/2400	77898	CART2-96/2400	77911
120	180	20	MHS-120-E2SAC	77852	SACPL-120/3000	77899	CART2-120/3000	77912

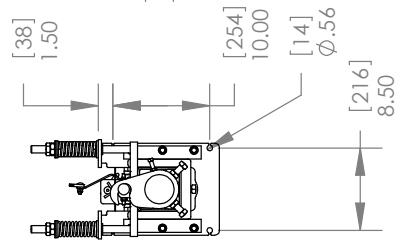
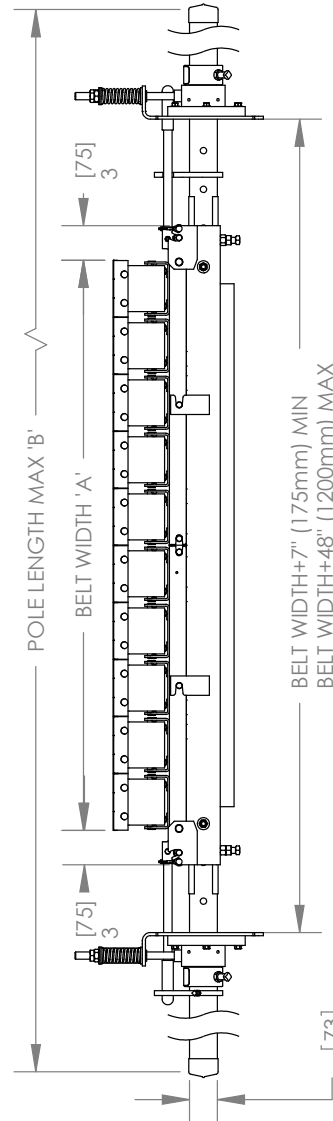
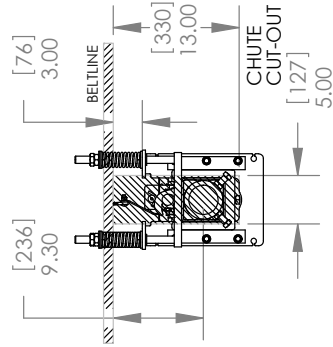
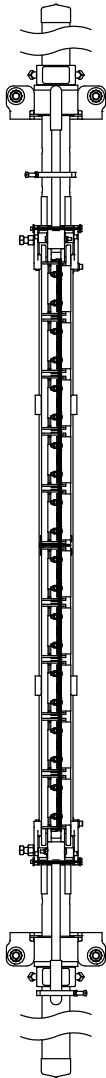

Section 8 - Specs and CAD Drawings

8.2 CAD Drawing - MHS ESAC with V-Tips - Dual Cartridge

SPECIFICATIONS			SAC MHS V CLEANER		SAC CENTER POLE		SA CARTRIDGE SET	
BELT WIDTH 'A' (in)	MAX POLE LENGTH 'B' (mm)	# OF BLADES	ORDER NUMBER	ITEM CODE	ORDER NUMBER	ITEM CODE	ORDER NUMBER	ITEM CODE
60	120	10	MHS-60V-E2SAC	77861	SACPL2-60/1500	77895	CART2-60/1500	77908
72	180	12	MHS-72V-E2SAC	77862	SACPL-72/1800	77896	CART2-72/1800	77909
84	2100	14	MHS-84V-E2SAC	77863	SACPL-84/2100	77897	CART2-84/2100	77910
96	2400	16	MHS-96V-E2SAC	77864	SACPL-96/2400	77898	CART2-96/2400	77911
120	3000	20	MHS-120V-E2SAC	77865	SACPL-120/3000	77899	CART2-120/3000	77912

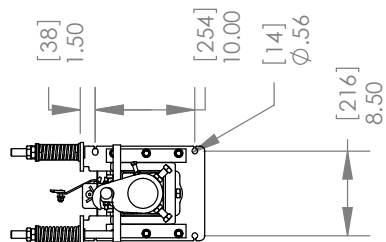
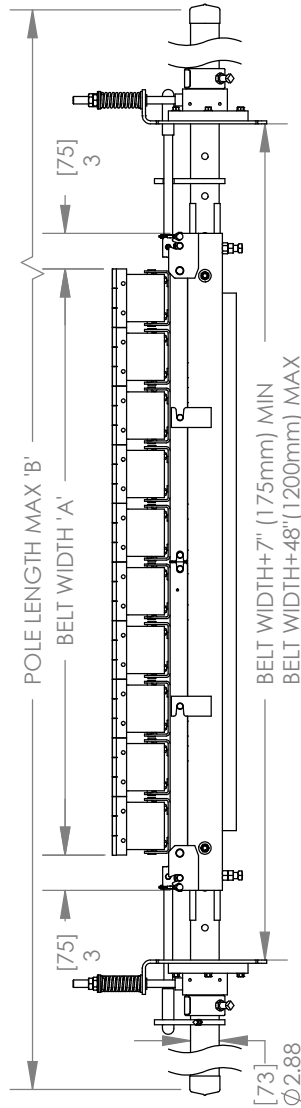
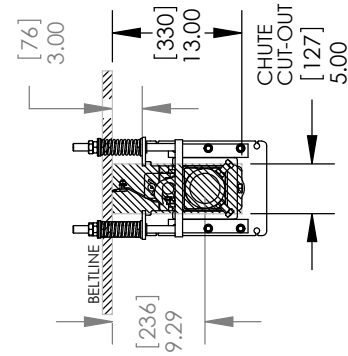
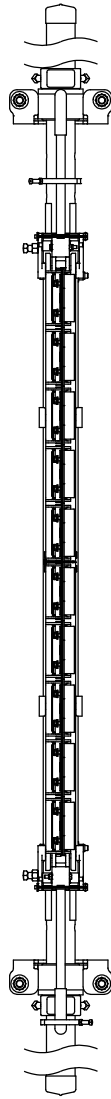

Section 9 - Replacement Parts

9.1 Replacement Parts List - MHS ESAC Secondary Cleaners

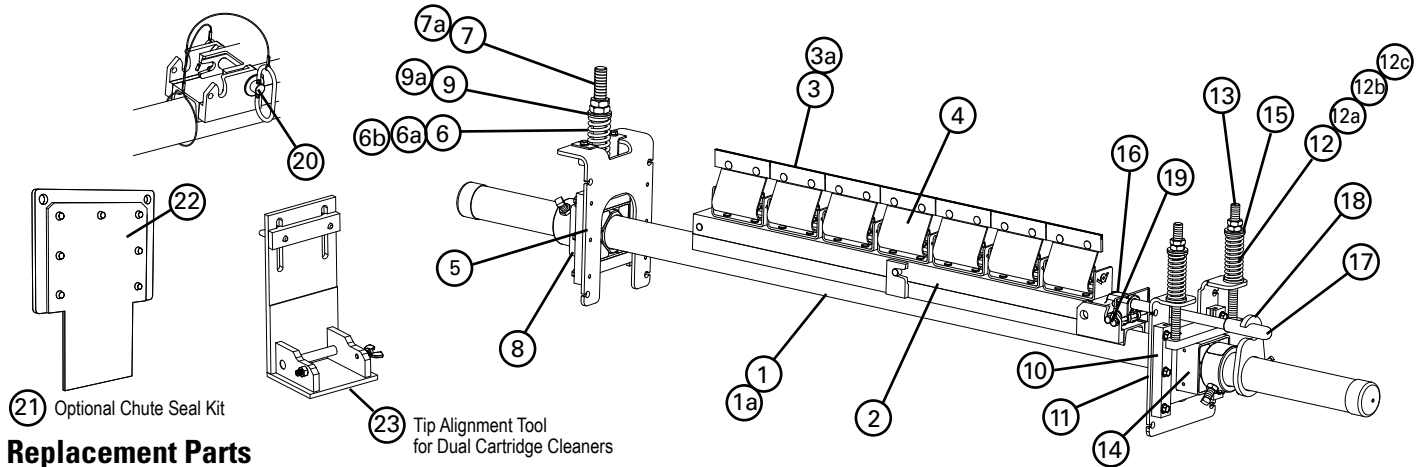

Replacement Parts

REF	DESCRIPTION	ORDERING NUMBER	ITEM CODE	WT. LBS.
1	ESAC Cartridge Pole 24"	SACPL-24/600	77887	65.4
	ESAC Cartridge Pole 30"	SACPL-30/750	77888	71.2
	ESAC Cartridge Pole 36"	SACPL-36/900	77889	77.1
	ESAC Cartridge Pole 42"	SACPL-42/1050	77890	82.9
	ESAC Cartridge Pole 48"	SACPL-48/1200	77891	88.8
	ESAC Cartridge Pole 54"	SACPL-54/1350	77892	94.6
	ESAC Cartridge Pole 60"	SACPL-60/1500	77893	100.5
	ESAC Cartridge Pole 72"	SACPL-72/1800	77894	112.2
	ESAC Cartridge Center Pole 60" (Dual)	SACPL2-60/1500	77895	77.3
	ESAC Cartridge Center Pole 72" (Dual)	SACPL2-72/1800	77896	89.5
	ESAC Cartridge Center Pole 84" (Dual)	SACPL2-84/2100	77897	101.8
	ESAC Cartridge Center Pole 96" (Dual)	SACPL2-96/2400	77898	114.1
	ESAC Cartridge Center Pole 120" (Dual)	SACPL2-120/3000	77899	142.3
1a	Extender Pole (for use with Dual Cartridge Center Pole)	MHP-EP	76392	54.0
2	ESAC Cartridge 24"	CART-24/600	77900	3.5
	ESAC Cartridge 30"	CART-30/750	77901	4.3
	ESAC Cartridge 36"	CART-36/900	77902	5.1
	ESAC Cartridge 42"	CART-42/1050	77903	5.9
	ESAC Cartridge 48"	CART-48/1200	77904	6.7
	ESAC Cartridge 54"	CART-54/1350	77905	7.4
	ESAC Cartridge 60"	CART-60/1500	77906	8.4
	ESAC Cartridge 72"	CART-72/1800	77907	10.0
	ESAC Cartridge 60" (Dual)	CART2-60/1500	77908	8.6
	ESAC Cartridge 72" (Dual)	CART2-72/1800	77909	10.2
	ESAC Cartridge 84" (Dual)	CART2-84/2100	77910	11.7
ESAC Cartridge 96" (Dual)	CART2-96/2400	77911	13.3	
ESAC Cartridge 120" (Dual)	CART2-120/3000	77912	16.8	
3	C-Tip*	ICT6	74535	0.7
3a	V-Tip* (for vulcanized belts only)	RSA150	73628	1.3
4	PowerFlex™ Cushion*	PFC	75927	4.2
5	SST HD Mounting Base Kit* (includes 1 mounting base and 2 slide guides)	SSTHDMK	77870	10.2
6	SST Spring - White (1 ea.) for belts 18"-30" (450-750 mm)	STS-W	75846	0.5
6a	SST Spring - Silver (1 ea.) for belts 36"-48" (900-1200 mm)	STS-S	75843	0.8
6b	SST Spring - Black (1 ea.) for belts 54"-84" (1350-2100 mm)	STS-B	75844	1.0
7	SST Adj Rod Kit* (incl. 1 rod, 2 nuts, 2 bushings, 1 washer) for belts 18"-60" (450-1500 mm)	STAK	75847	2.9
7a	SST HD Adj Rod Kit* (incl. 1 rod, 2 nuts, 2 HD bushings, 1 washer) for belts 72"-84" (1800-2100 mm)	STAKHD	75892	3.0

REF	DESCRIPTION	ORDERING NUMBER	ITEM CODE	WT. LBS.
8	SST HD Torsion Pole Mount* (1 ea.)	SSTHDPM	77868	15.0
9	SST Bushing Kit - White/Silver	SSTBK-W	76636	0.1
9a	SST Bushing Kit - Black	SSTBK-B	76637	0.1
10	ST Slide Guide Kit	STGK2	77867	1.1
-	SST HD Cartridge Tensioner - White (includes 1 ea. item 5, 6, 7, 8) for belts 18"-30" (450-750 mm)	SST1HD-W	77876	30.3
-	SST HD Cartridge Tensioner - Silver (includes 1 ea. item 5, 6a, 7, 8) for belts 36"-48" (900-1200 mm)	SST1HD-S	77877	30.7
-	SST HD Cartridge Tensioner - Black (includes 1 ea. item 5, 6b, 7a, 8) for belts 54"-84" (1350-2100 mm)	SST1HD-B	77878	31.0
11	CST HD Mounting Base Kit*	CSTHDMK	77871	8.5
12	CST Spring - White (1 ea.) for belts 18"-30" (450-750 mm)	CTS-W	77742	0.5
12a	CST Spring - Silver (1 ea.) for belts 36"-48" (900-1200 mm)	CTS-S	77743	0.5
12b	CST Spring - Black (1 ea.) for belts 54"-84" (1350-2100 mm)	CTS-B	77744	0.6
12c	CST Spring - Gold (1 ea.) for belts 96"-120" (2400-3000 mm)	CTS-G	77745	0.8
13	CST Adj Rod Kit (incl. 2 rods, 4 nuts, 4 bushings, 2 washers)	CSTAK	77031	3.3
14	CST HD Torsion Pole Mount* (1 ea.)	CSTHDPM	77869	16.4
15	CST Bushing Kit (includes 4 bushings)	CSTBK	77037	0.1
-	CST HD Cartridge Tensioner - White (incl. 1 ea. item 11, 13, 14 and 2 ea. item 12) for belts 18"-30" (450-750 mm)	CST1HD-W	77872	30.1
-	CST HD Cartridge Tensioner - Silver (incl. 1 ea. item 11, 13, 14 and 2 ea. item 12a) for belts 36"-48" (900-1200 mm)	CST1HD-S	77873	30.1
-	CST HD Cartridge Tensioner - Black (includes 1 ea. item 11, 13, 14 and 2 ea. item 12b) for belts 54"-84" (1350-2100 mm)	CST1HD-B	77874	30.1
-	CST HD Cartridge Tensioner - Gold (includes 1 ea. item 11, 13, 14 and 2 ea. item 12c) for belts 96"-120" (2400-3000 mm)	CST1HD-G	77875	30.7
16	ESAC Removal Knuckle	SACRKN	77882	3.2
17	ESAC Removal Handle	SACRH	77883	3.0
18	ESAC Handle Lock Plate	SACRHL	77884	1.7
19	Knuckle Retainer Pin	SACKRP	77885	0.2
20	SAC Hitch Pin	SACHP2	77768	0.9
-	ESAC Removal Kit (includes 1 ea. item 16, 17, 18, 19, 20)	SACRKT	77886	9.0
21	ESAC Chute Seal Kit	SACSK	77052	3.9
22	ESAC Chute Seal Replacement Cover	SACSRC	77065	0.5
23	ESAC Cartridge Tip Alignment Tool (Dual)	SAC2-TIP-TL	77866	2.5

*Hardware Included
Lead Time: 1 working day

Section 10 - Other Flexco Conveyor Products

Flexco provides many conveyor products that help your conveyors to run more efficiently and safely. These components solve typical conveyor problems and improve productivity. Here is a quick overview on just a few of them:

MMP Precleaner



- Extra cleaning power right on the head pulley
- A 10" (250mm) TuffShear™ blade provides increased blade tension on the belt to peel off abrasive materials
- The unique Visual Tension Check™ ensures optimal blade tensioning and quick, accurate retensioning
- Easy to install and simple to service

DRX Impact Beds



- Exclusive Velocity Reduction Technology™ to better protect the belt
- Slide-Out Service™ gives direct access to all impact bars for change-out
- Impact bar supports for longer bar life
- 4 models to custom fit to the application

MDWS DryWipe Secondary Cleaner



- Wipes the belt dry as final cleaner in system
- Automatic blade tensioning to the belt
- Easy, visual blade tension check
- Simple, one-pin blade replacement

PT Max™ Belt Trainer



- Patented "pivot & tilt" design for superior training action
- Dual sensor rollers on each side to minimize belt damage
- Pivot point guaranteed not to freeze up
- Available for topside and return side belts

Flexco Specialty Belt Cleaners



- "Limited space" cleaners for tight conveyor applications
- High Temp cleaners for severe, high heat applications
- A rubber fingered cleaner for chevron and raised rib belts
- Multiple cleaner styles in stainless steel for corrosive applications

Belt Plows



- A belt cleaner for the tail pulley
- Exclusive blade design quickly spirals debris off the belt
- Economical and easy to service
- Available in vee or diagonal models

The Flexco Vision

To become the leader in maximising
belt conveyor productivity for our customers worldwide
through superior service and innovation.



2525 Wisconsin Avenue • Downers Grove, IL 60515-4200 • USA
Tel: (630) 971-0150 • Fax: (630) 971-1180 • E-mail: info@flexco.com

Visit www.flexco.com for other Flexco locations and products.

©2014 Flexible Steel Lacing Company. 11/14. For Reorder: X2359

